

16 October 2023

See Distribution List

Dear Sir/Madam

ADDENDUM NO.2 TO THE CODE OF PRACTICE ON SURFACE WATER DRAINAGE (7TH EDITION)

This circular informs Developers, Qualified Persons (QP) and Agencies that PUB will be issuing Addendum no. 2 to the Code of Practice on Surface Water Drainage (COPSWD) (7th Edition) on 16 October 2023.

Enhancing Protection of New or Redeveloping Infrastructure that Deliver Essential Services

2 Climate change is a long-term existential challenge which has brought rising sea levels and extreme weather patterns. Across the globe, countries and cities have suffered from severe flooding. Infrastructure that deliver essential services were affected, which caused significant disruptions to daily life, and threatened access to food, water, and energy.

3 PUB has informed via the earlier circular on 1 June 2023 of the new requirements which will be added into the COPSWD (7th Edition) to enhance flood protection of Critical Infrastructure (CI) and Key Infrastructure (KI)¹ in Singapore (Refer to Annex A for the full list of changes).

4 QPs will need to advise the developers and owners of CIs or KIs on the need to comply with the new requirements and adequately protect critical M&E equipment within the developments. QPs shall also pre-consult PUB via pub_one@pub.gov.sg on the required MPL before embarking on site design of CIs or KIs, some of which may be integrated with a larger development (e.g. Distribution Substations).

¹ "Critical Infrastructure" (CI) and "Key Infrastructure" (KI) are new terminologies introduced in this Addendum. Please refer to Annex A for their definition.

5 Agencies with upcoming CI or KI developments are reminded to inform their appointed QPs on the CI or KI status of the development and pre-consult PUB on the required MPL before embarking on site design. Agencies can do so via the *Planning Consultation Checking System (PCCS)* at <https://pccs.pub.gov.sg>. Agencies without access to this platform may also contact the following officers:

Location of CI or KI	Officer-in-Charge	Email
Western/Northwestern region (e.g. Tuas, Jurong, Upp Bt Timah, Bt Batok, Bt Panjang, Choa Chu Kang, Lim Chu Kang)	Mr Idaly Mamat	Idaly_MAMAT@pub.gov.sg
Central region (e.g. CBD, Bt Timah, Queenstown, Bishan, Kallang, Geylang)	Ms Pratheipa Rajendram	Pratheipa_RAJENDRAM@pub.gov.sg
Eastern/Northeastern region (e.g. Changi, Punggol, Sengkang, Ang Mo Kio, Woodlands, Sembawang)	Ms Loh Yee Wen	LOH_Yee_Wen@pub.gov.sg

Additional changes to the COPSWD in Addendum no.2.

6 Addendum no.2 also includes additional changes to existing clauses in the COPSWD for better clarity, alignment with existing practices and to require co-signatory by ABC Waters Professionals (ABCWP) who are Accredited Landscape Architects or registered Professional Architects in Development Control submissions for projects with ABC Waters design features.

Queries on the Circular

7 If you have any queries, you may contact Mr. Derrick Low at derrick_low@pub.gov.sg or Mr. Daniel Tio at daniel_tio@pub.gov.sg.

Yours faithfully



Joanne Siew (Ms.)
Deputy Director
Catchment and Waterways Department
PUB, Singapore's National Water Agency

Annex A – COPSWD Changes to Enhance Protection to CI/KI

Clause	COP 7 th Edition Existing Clause	Amended Clause	Remarks on Changes
Terminology	(None)	“Critical Infrastructure” (CI) refers to physical infrastructure and assets that are vital to the continued delivery of the essential services that Singapore relies on, the loss or compromise of which would lead to a debilitating impact on security, economy or public health and safety;	New clause
Terminology	(None)	“Key Infrastructure” (KI) refers to developments that fall outside the definition of a critical infrastructure, but are identified by agencies to be important to agencies’ function, such as distribution substations (22kV, 6.6kV), prison complexes, bus interchange and depots, and neighbourhood police centres;	New clause
Terminology	(None)	“Critical M&E Equipment” refers to power (e.g. distribution substations, transformers, standby generator sets), communication (e.g. main distribution frame rooms, server rooms) and other M&E equipment deemed as critical by the asset owner;	New clause
Terminology	“Special Facilities” refers to developments such as Rapid Transit systems, port/aviation facilities, wafer fabrication plants, underground road networks, power generation plants, healthcare with A&E services, gas transmission/ receiving station or any developments as specified by the Board;	“Special Facilities” refers to developments such as Rapid Transit systems, port/aviation facilities, wafer fabrication plants, underground road networks, power generation plants, healthcare with A&E services, gas transmission/ receiving station, transmission substations, exchange or central office used for telecommunication purpose, or any developments as specified by the Board;	Additions to existing clause

Clause	COP 7 th Edition Existing Clause	Amended Clause	Remarks on Changes
2.1.1 (b)	<p><u>Industrial/ Institutional/Commercial/Multi-Unit Residential Developments</u></p> <p>The minimum platform level shall not be lower than:</p> <p>(i) 4.0m above Singapore Height Datum for developments along the southern coast; and 4.5m above Singapore Height Datum for developments along the northern coast; or</p> <p>(ii) 600 mm above the adjacent road/ground level; or</p> <p>(iii) Any other level as may be specified by the Board;</p> <p>whichever is the highest.</p>	<p><u>Industrial/ Institutional/Commercial/Multi-Unit Residential Developments</u></p> <p>The minimum platform level shall not be lower than:</p> <p>(i) 4.0m above Singapore Height Datum for developments along the southern coast; and 4.5m above Singapore Height Datum for developments along the northern coast; or</p> <p>(ii) 600 mm above the adjacent road/ground level; or</p> <p>(iii) 300mm above modelled flood levels (as advised by the Board) if the development is a CI or KI</p> <p>(iv) Any other level as may be specified by the Board;</p> <p>whichever is the highest.</p>	<p>To request for information during consultation stage if the development is a CI or KI.</p> <p>Note that the additional requirement for this clause is only applicable to CI and KI.</p>
2.1.1 (c)	<p><u>Special Facilities and Developments with Direct or Indirect Linkages to Underground Special Facilities</u></p> <p>The minimum platform level shall not be lower than:</p> <p>(i) 4.0m above Singapore Height Datum for developments along the southern coast; and 4.5m above Singapore Height Datum for developments along the northern coast; or</p> <p>(ii) 1 m above the adjacent road/ground level; or</p> <p>(iii) Any other level as may be specified by the Board;</p> <p>whichever is the highest</p>	<p><u>Special Facilities and Developments with Direct or Indirect Linkages to Underground Special Facilities</u></p> <p>The minimum platform level shall not be lower than:</p> <p>(i) 4.0m above Singapore Height Datum for developments along the southern coast; and 4.5m above Singapore Height Datum for developments along the northern coast; or</p> <p>(ii) 1 m above the adjacent road/ground level; or</p> <p>(iii) 300mm above modelled flood levels (as advised by the Board) if the development is a CI or KI</p> <p>(iv) Any other level as may be specified by the Board;</p> <p>whichever is the highest.</p>	(As above)

Clause	COP 7 th Edition Existing Clause	Amended Clause	Remarks on Changes
2.5	<i>(None)</i>	<p>2.5 Critical M&E equipment in Critical Infrastructure / Key Infrastructure:</p> <p>The QP shall advise the developer/owner on the need to identify power, communications, and other critical M&E equipment prior to the design of the development site.</p> <p>Critical M&E equipment shall be located /installed at the minimum platform level or higher.</p> <p>For critical M&E equipment located at the basement, the structural crest level for all entrances, exits and openings leading to the basement must comply with crest level requirements as stipulated in Clause 2.2.</p>	New clause

Annex B – Additional COPSWD Changes Included in Addendum No.2

Clause	COP 7 th Edition Existing Clause	Amended Clause	Remarks on Changes
2.2 (c)	(c) <u>Underground Special Facilities and Developments with Direct or Indirect Linkages to Underground Special Facilities.</u>	(c) <u>Special Facilities and Developments with Direct or Indirect Linkages to Special Facilities.</u>	Removed “Underground”, as the parent Clause 2.2 already refers to basements and underground structures.
4.3.3.	<u>Culverts Across Roads</u> Only box culverts shall be provided. The internal width and clear depth of a box culvert shall be at least 600 mm. For culverts across expressways and semi-expressways, the minimum size shall be 1.0 m x 1.0 m.	<u>Culverts Across Roads</u> Only box culverts shall be provided. The internal width and clear depth of a box culvert shall be at least 1.0m. For culverts across expressways and semi-expressways, the minimum size shall be 2.0 m (width) x 1.5 m (depth).	Increase in culvert sizes to cater for adequate human-access and usage of small machinery and equipment.
6.3.3	Permit to Start Earthworks The site operator/contractor shall obtain a written permission (or a clearance certificate) from the Board and implement adequate ECM before the commencement of any earthwork.	Approval to Start Earthworks The site operator/contractor shall obtain approval from the Board and implement adequate ECM before the commencement of any earthwork.	Editorial changes.
7.1.5	(a) New erection and reconstruction works to commercial, industrial, institutional and residential developments greater than or equal to 0.2 hectares in size; and (b) Additions & Alterations (A&A) works to existing commercial, industrial, institutional and residential developments where affected area is greater than or equal to 0.2 hectares in size such as: ...Peak runoff reduction can be achieved through the implementation of ABC Waters design features and/or structural detention and retention features, such as: (i) Detention tanks; (ii) Retention/sedimentation ponds; (iii) Wetlands; (iv) Bioretention swales; (v) Bioretention basins or rain gardens; (vi) Porous pavements, etc.	(a) New erection and reconstruction works to all developments greater than or equal to 0.2 hectares in size; and (b) Additions & Alterations (A&A) works to all existing developments where affected area is greater than or equal to 0.2 hectares in size such as: ...Peak runoff reduction can be achieved through the implementation of ABC Waters design features and/or structural detention and retention features, such as: (i) Detention tanks/drains; (ii) Retention/sedimentation ponds; (iii) Wetlands; (iv) Bioretention swales; (v) Bioretention basins or rain gardens; (vi) Porous pavements, etc.	All sites ≥0.2 Ha need to reduce peak runoff. Peak runoff can be reduced via use of detention drains.

Clause	COP 7 th Edition Existing Clause	Amended Clause	Remarks on Changes
8.2.2	<p>The developer/ owner shall engage an ABC Waters (Active, Beautiful, Clean Waters) Professional to design, oversee the construction of, and develop a maintenance plan for the ABC Waters design features.</p> <p>The developer/owner shall submit the concept design and design calculations, endorsed by the ABC Waters Professional, to the Board as part of DC submission.</p> <p>Hydraulic calculations associated with the ABC Waters design features, endorsed by an ABC Waters Professional who is a PE (Civil), shall be submitted at DC stage.</p> <p>If there is any change to the catchment or design of the ABC Waters design features subsequent to DC approval, QP shall submit the updated design and hydraulic calculations associated with the ABC Waters design features, duly endorsed by an ABC Waters Professional who is a PE (Civil).</p>	<p>The developer/ owner shall engage an ABC Waters (Active, Beautiful, Clean Waters) Professionals to plan, design, oversee the construction of, and develop a maintenance plan for the ABC Waters design features.</p> <p>For developments of area exceeding 0.4 hectares, DC submissions for ABC Waters design features, comprising the following items, should be submitted to the Board as part of DC submission:</p> <ul style="list-style-type: none"> (a) Hydraulic calculations for the ABC Waters design features, endorsed by an ABC Waters Professional who is a PE (Civil). The calculation shall be accompanied by completed relevant design templates in Excel format, available on the PUB website. (b) Catchment/location plan of ABC Waters design features endorsed by an ABC Waters Professional who is an Accredited Landscape Architect or a registered Professional Architect. (c) Design drawings and maintenance checklists endorsed by an ABC Waters Professional of any profession. <p>If there is any change to the catchment or design of the ABC Waters design features subsequent to DC approval, QP shall submit a DC amendment with the full set of updated items (a), (b) and (c) above with respective endorsement and a summary table for all the amendments.</p>	<p>Requirement for ABCWP(LA) or ABCWP(Ar) to be a co-signatory in DC submissions for developments >0.4ha with ABC Waters design features, as they are responsible for and involved in the design concept.</p>

Clause	COP 7 th Edition Existing Clause	Amended Clause	Remarks on Changes
9.4	<p>Sump for Drain Intersections</p> <p>A sump of sufficient size shall be provided where drains converge. The minimum internal width of the sump shall not be less than 1.5 times the width of the drain leading away from the sump.</p> <p>Drains shall enter the sump at angles less than a right angle and at different levels wherever possible. The invert level of the downstream drain shall be lower than the invert level of the sump so that no stagnant water will collect in the sump.</p>	<p>Sump for Drain Intersections</p> <p>A sump of sufficient size shall be provided where drains converge. The minimum internal width of the sump shall not be less than 1.5 times the width of the drain leading away from the sump.</p> <p>Drains connecting into the sump shall not form an acute angle with the outgoing drain flow and shall connect at different levels wherever possible. The invert level of the downstream drain shall be lower than the invert level of the sump so that no stagnant water will collect in the sump.</p>	To clarify that drain connections shall not form an acute angle with the outgoing drain flow.
9.8.1	<p>Drop-inlet Chambers, Inlet Openings and Slot-Outlets</p> <p>Runoff from road carriageways (including viaducts) and carparks shall be effectively drained away to prevent water stagnation and to ensure road safety. Drop-inlet chambers and concealed scupper drainage shall be designed in accordance with the Land Transport Authority's latest Standard Details of Road Elements and shall be provided at maximum 6 m spacings along all road carriageways. For curves and bends, inlet openings shall be provided at every 3m interval.</p>	<p>Drop-inlet Chambers, Inlet Openings and Slot-Outlets</p> <p>Runoff from road carriageways (including viaducts) and carparks shall be effectively drained away to prevent water stagnation and to ensure road safety. Drop-inlet chambers and concealed scupper drainage shall be designed in accordance with the Land Transport Authority's latest Standard Details of Road Elements and shall be provided at maximum 6 m spacings along all road carriageways. Intermediate sump shall be provided if the length of the concealed scupper drainage exceeds 6m. For curves and bends, inlet openings shall be provided at every 3m interval.</p>	To align with existing practice.
9.9	<p>Safety Railings</p> <p>Standard safety railings shall be provided for all open drains more than 1.0 m deep. "Type B" railings as specified in Land Transport Authority's latest Standard Details of Road Elements shall be installed for new open drains. Otherwise, railings as specified in Drawing No.6, to match the existing railings on site, shall be installed when requested by the Board.</p>	<p>Safety Railings</p> <p>Standard safety railings shall be provided for all open drains more than 1.0 m deep. "Type A" railings as specified in Land Transport Authority's latest Standard Details of Road Elements shall be installed for new open drains. Otherwise, railings as specified in Drawing No.6, to match the existing railings on site, shall be installed when requested by the Board.</p>	To align with existing practice.

Clause	COP 7 th Edition Existing Clause	Amended Clause	Remarks on Changes
9.12.2	<p>Entrance Culvert/Crossing</p> <p>Under the exceptional circumstance where the entrance culvert/crossing is shallower than 600 mm or when requested by the Board, hinged open gratings shall be installed throughout the whole length of the entrance culvert/crossing.</p>	<p>Entrance Culvert/Crossing</p> <p>Under the exceptional circumstance where the entrance culvert/crossing is shallower than 600 mm or when requested by the Board, one number of hinged open gratings as per Drawing no. 7C shall be installed in the middle of the entrance culvert/crossing</p>	<p>To standardise entrance culvert grating design and align with LTA's SDRE requirements. See Annex C for the new Drawing no. 7C.</p>

Annex C – Drawing No. 7C

This drawing shows schematically the drainage facilities and minimum structural requirements. Details of the structural, geotechnical and foundation systems are to be designed by Qualified Persons.

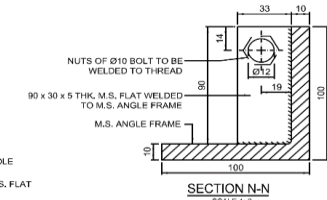
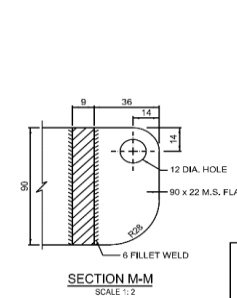
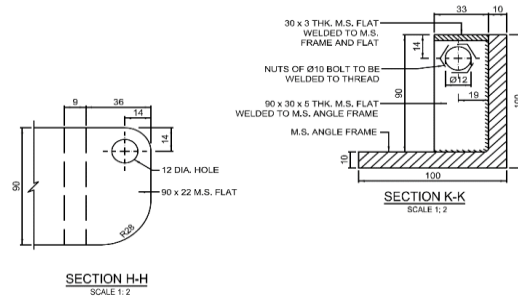
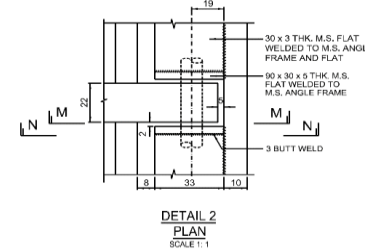
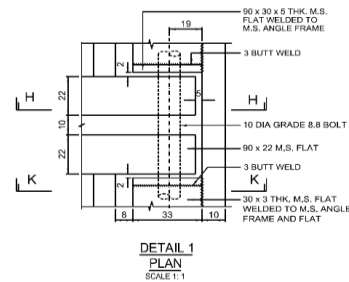
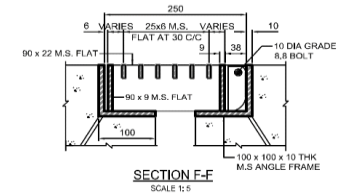
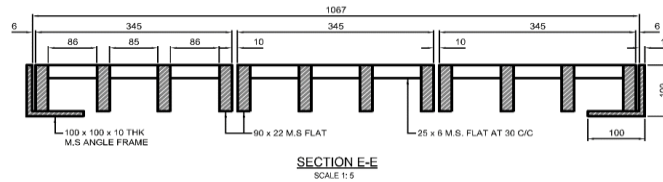
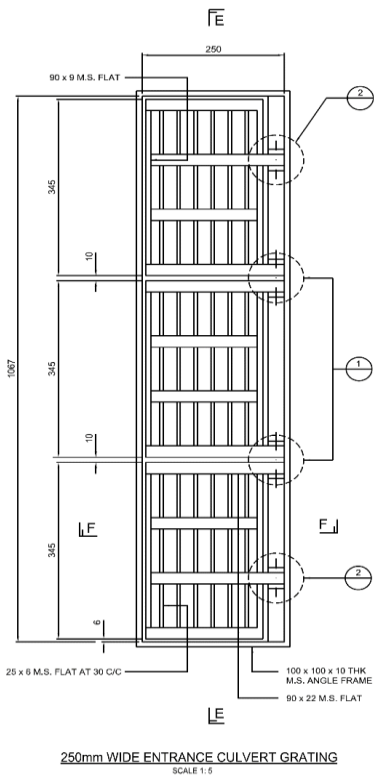

- NOTES:**
1. ALL DIMENSIONS SHOWN ARE IN MILLIMETRES UNLESS OTHERWISE STATED.
 2. GRATINGS AND FRAMES ARE SHOP FABRICATED AND ALL WELD SLAGS REMOVED.
 3. THE COMPLETE ASSEMBLY EXCEPT FISHTAILS IS GALVANISED BY HOT-DIP GALVANISING PROCESS IN ACCORDANCE WITH ISO 1461:2009.
 4. FISHTAILS ARE WELDED TO M.S. ANGLE AND PLACED AT ALL CORNERS OF THE M.S. FRAME.
 5. ALL THE FLATS AND ANGLES ARE FILLET WELDED THROUGHOUT.
 6. ALTHOUGH THE M.S. GRATINGS DESIGNED REMAIN IN ITS POSITION WHEN OPENED MORE THAN 106°, ADEQUATE MEASURES SHOULD NONETHELESS BE TAKEN TO PREVENT IT FROM ACCIDENTALLY CLOSING WHEN IT IS OPENED.

DRAWING NO. 7C

TYPICAL DETAILS OF ENTRANCE CULVERT GRATINGS

DISTRIBUTION (via e-mail):

Inter-Agency Coordinating Committee (IACC) members

All Corenet e-info subscribers

President
Association of Consulting Engineers, Singapore (ACES)
18 Sin Ming Lane #06 - 01
Midview City
Singapore 573960
secretariat@aces.org.sg

President
Institution of Engineers, Singapore (IES)
70 Bukit Tinggi Road
Singapore 289758
ies@iesnet.org.sg

President
Real Estate Developers' Association of Singapore (REDAS)
190 Clemenceau Avenue #07-01
Singapore Shopping Centre
Singapore 239924
enquiry@redas.com

President
Singapore Contractors Association Limited (SCAL)
Construction House
1 Bukit Merah Lane 2
Singapore 159760
enquiry@scal.com.sg

President
Singapore Institute of Architects (SIA)
79/79A/79B Neil Road
Singapore 088904
info@sia.org.sg

President
Singapore Plumbing Society (SPS)
117B Jalan Besar Lvl 3
Singapore 208837
sps@plumbing.org.sg

President
Professional Engineers Board, Singapore (PEB)
52 Jurong Gateway Road, #07-03
Singapore 608550
registrar@peb.gov.sg

President
Board of Architects Singapore (BOA)
5 Maxwell Road
1st Storey Tower Block
MND Complex
Singapore 069110
boa_enquiry@boa.gov.sg